

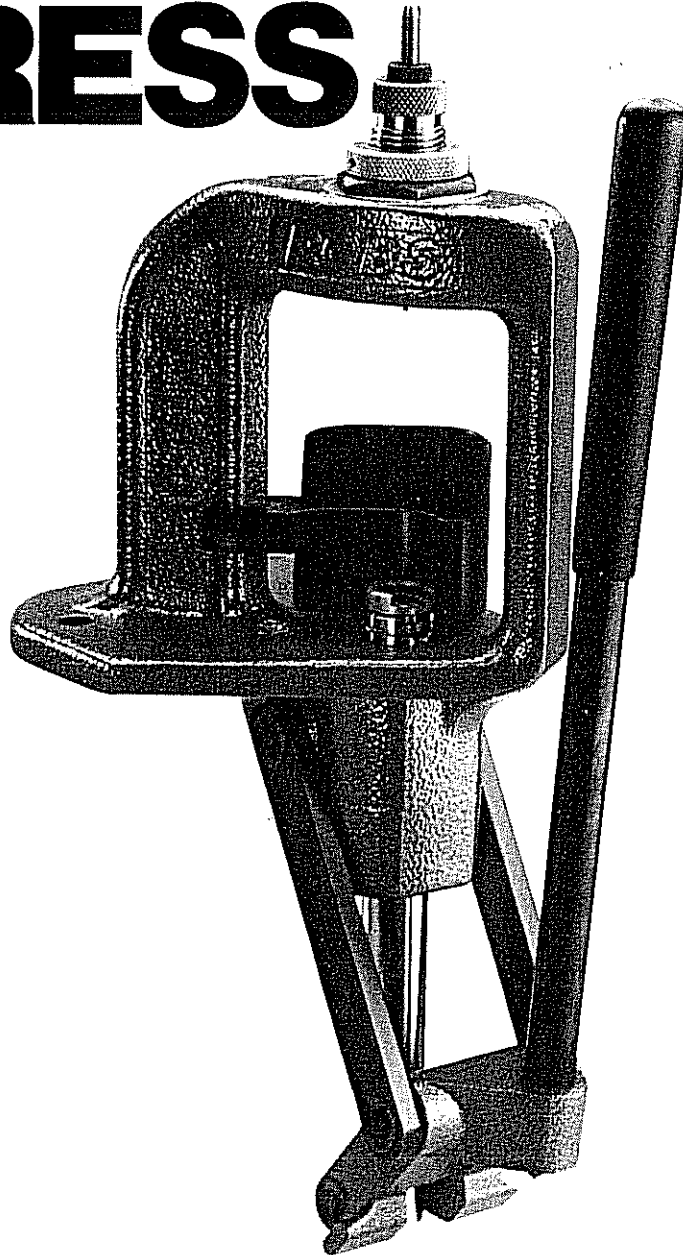

RELOADER SPECIAL-3 PRESS



Safety and Operating Instructions

SAFETY

Reloading is an enjoyable and rewarding hobby that is easily conducted with safety. But carelessness or negligence can make reloading hazardous. This Press has been designed from the beginning with the user's safety in mind.

As when loading with any other reloading press, some safety rules must be followed. By observing these few rules, the chance of a hazardous occurrence causing damage or injury becomes extremely remote.

GENERAL

- Use the reloading equipment as the manufacturer recommends. Study the instructions carefully and become thoroughly familiar with the operation of the tool. Don't take short cuts.
- Observe "good housekeeping" in the reloading area. Keep tools and components neat, clean and orderly. Promptly and completely clean up primer and powder spills.
- Reload only when you can give your undivided attention. Do not reload when fatigued or ill. Develop a reloading routine to avoid mistakes. Avoid haste—load at a leisurely pace.
- Always wear adequate eye protection. You assume unnecessary risk when reloading without wearing safety glasses.
- If any unusual resistance is encountered when moving the operating handle, STOP IMMEDIATELY and investigate the cause. To proceed against unusual resistance may damage equipment and/or cause serious injury!

LOADING DATA

- Use only laboratory tested reloading data. We highly recommend the use of the SPEER Reloading Manual.
- OBSERVE ALL WARNINGS ABOUT THE USE OF MAXIMUM LISTED LOADS.

PRIMERS AND POWDER

- Store primers and powder beyond the reach of children and away from heat, dampness, open flames and electrical equipment.
- DO NOT use primers of unknown identity. To destroy unwanted primers, soak in oil for a few days and then bury.
- Keep primers in original factory container until ready to use. Return unused primers to the same factory packaging for safety and to preserve their identity.
- DO NOT store primers in bulk. The blast of just a few hundred primers is sufficient to cause serious injury to anyone nearby.
- DO NOT force primers. Use care in handling primers.
- DO NOT use any powder unless its identity is positively known. Discard all mixed powders and those of uncertain or unknown identity.
- If you use a Powder Measure, replace the lids on both the Powder Hopper and powder can after the Powder Hopper has been filled.
- Before charging cases, settle the powder in the Powder Hopper. Throw and check the weight of at least ten charges. This will assure you that the correct powder charge is being thrown.
- After a reloading session ends, pour the remaining powder back in its original factory container. This will preserve the identity and shelf life of the powder.
- DO NOT smoke while handling powder or primers.

RECORD KEEPING

- Keep complete records of reloads. Apply a descriptive label to each box showing the date produced, and the primer, powder and bullet used. Labels for this purpose are packed with SPEER bullets.

Since Omark Industries has no control over the choice of components, the manner in which they are assembled, the use of this press, or the guns in which the resulting ammunition may be used, no responsibility, either expressed or implied, is assumed for the use of ammunition reloaded with this press.

INTRODUCTION

The RCBS Reloader Special 3 (RS 3) Press is the perfect press for newcomers to reloading. It has evolved from the now famous "JR" and Reloader Special Presses. The RS 3 is identical to its predecessor, the RS 2, with the exception of the bushing added to the top of the press. With the RS 3 you can reload your favorite rifle or pistol ammo – from the magnums down to .17 caliber. Because of the patented RCBS Compound Leverage System you can resize cases their full length, form .30-06 cases into many other calibers, and utilize the full range of RCBS accessories.

The sturdy block "O" frame, pioneered by RCBS, eliminates springing of the frame that occurs in "C" and other type presses. The block "O" portion of the frame has been offset to allow easy access of the work area. The press frame has an extra-long ram-bearing surface to eliminate ram wobble and side-play and assures perfect alignment of the shell holder to the die. The RS 3 Press has standard $\frac{7}{8}$ -14 thread for all popular reloading accessories. The toggle block, links and pins are engineered to prevent springing and breakage.

ACCESSORIES INCLUDED WITH THE RELOADER SPECIAL 3 PRESS

The RS 3 Press is designed to utilize the Ram™ Priming Unit attachment. This includes the Ram Priming Body, Primer Rod Holder and large and small Primer Rod Assemblies. The Ram Priming Body threads into the $\frac{7}{8}$ -14 press hole and accepts standard Shell Holders. The Primer Rod Holder snaps into the ram and holds the Primer Rod Assembly.

A redesigned Primer Catcher snaps directly onto the press frame for easy emptying. Spent primers drop through the partially hollow ram, out the back and into the Primer Catcher.

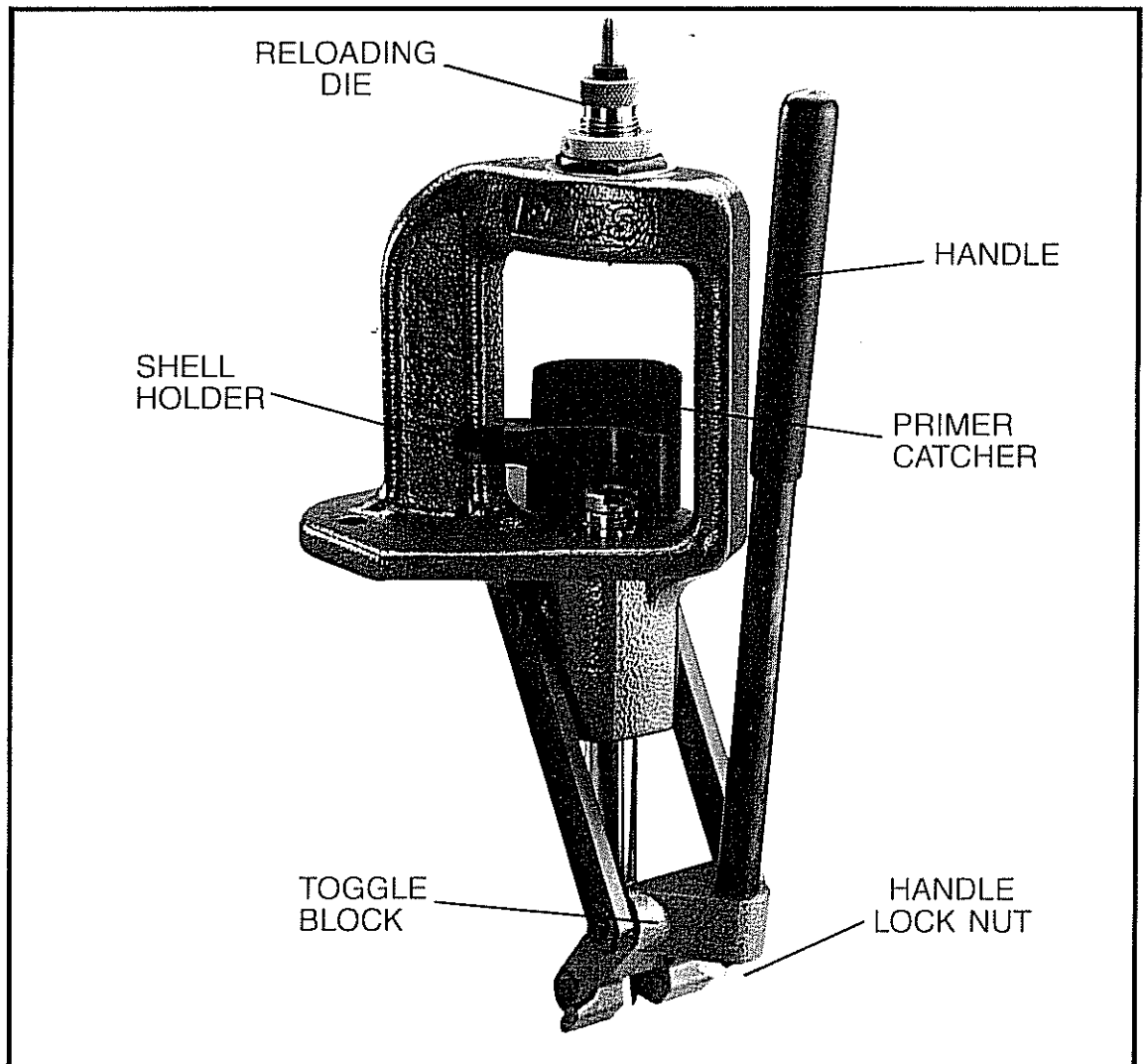

UNPACKING

Unpack the press carefully and look for the items listed below. Refer to the parts list for identification.

- Press
- Handle and Handle Nut
- Primer Catcher
- Resizing Lubricant
- Ram Priming Unit
- Reloading Dies and Shell Holder if purchased as a "Combo."

Report any shortage to your dealer immediately.

INSTALLATION

Mount the RS 3 Press to a table or workbench with two $\frac{3}{8}$ " bolts of sufficient length to penetrate the press base and bench. For temporary use the press can be mounted to a bench or table with two "C" clamps.

Remove the handle nut from the handle and install the threaded portion through the toggle as shown. Attach the handle nut and tighten firmly. The handle nut must remain tight at all times to avoid damage to the handle and toggle.

To position the Primer Catcher as shown, snap the catcher onto the rear portion of the frame and against the ram.

The RS 3 Press ram accepts removable type Shell Holders. To install, insert the Shell Holder into the ram and twist slightly to the left. To remove, twist slightly to the right.

PRIMING

Many experienced reloaders have primed cases "off-press" with one of the hand-held or bench mounted priming tools. Some reloading presses simply do not have sufficient mechanical advantage at the priming position of the stroke to adequately seat primers.

Your RS 3 Press is supplied with an accessory Ram™ Priming Unit. The installation and operational procedure to "seat primers by feel" is as follows:

1. Remove conventional Shell Holder from ram.
2. Install Primer Rod Holder in ram.
3. Screw the Ram Priming Body into the press, positioning it so the Hex Lock Nut is even with the top of the threads of the body and so the shell holder slot is facing the front. Secure by tightening the $\frac{7}{8}$ -14 Hex Lock Nut.
4. Insert appropriate Shell Holder into Ram Priming Body.
5. Assemble large or small Primer Rod Assembly as appropriate. To assemble the Primer Rod Assemblies: Select the correct Primer Plug and Sleeve (large or small). Drop the Primer Plug through the Sleeve. Place the Spring on top of the Primer Rod. Screw the Primer Plug into the top of the Primer Rod. Tighten the assembly with a small nail or straightened paper clip through the hole in the Primer Plug. Do not over tighten.
6. Position the ram at the top of its stroke and drop the Primer Rod Assembly through the Shell Holder. It should come to rest extending approximately $\frac{1}{2}$ inch above the Shell Holder (see fig. 1).

To prime, simply place the primer into the extended Primer Rod Assembly (see Fig. 2). Raise the operating handle slightly so that the Primer Rod Assembly has dropped below the Shell Holder level. Insert deprimed cartridge case (see fig. 3) and lower the operating handle until the primer is seated.

Proper primer seating requires that the primer be seated between .002 inch and .006 inch below the case head. Either insufficient or excessive primer seating depth greatly decrease primer sensitivity and can result in misfires. Due to the mechanical advantage of this press, it is possible to over-seat or crush primers during seating. Care must be exercised until you learn the proper "feel."

An optional, and perhaps more precise method of primer seating known as "seating primers to a positive stop" is as follows:

7. Repeat steps 1-6.
8. Untighten $\frac{7}{8}$ -14 Hex Lock Nut and unscrew Ram Priming Body approximately $\frac{1}{2}$ inch until proper primer seating is achieved exactly at the end of the ram stroke. Proper adjustment can be achieved only by trial and error.

Subsequent primer seating depth using the "seating primers to a positive stop" method will vary only as much as the variation in the rim thickness of your cartridge cases.

Priming should be accomplished following either procedure consistently.

If you desire the additional convenience of an automatic primer feed, the RCBS Automatic Priming Tool is so equipped. It is produced to the same high quality and performance standards as your RS 3 Press and is available from your dealer.

Fig. 1

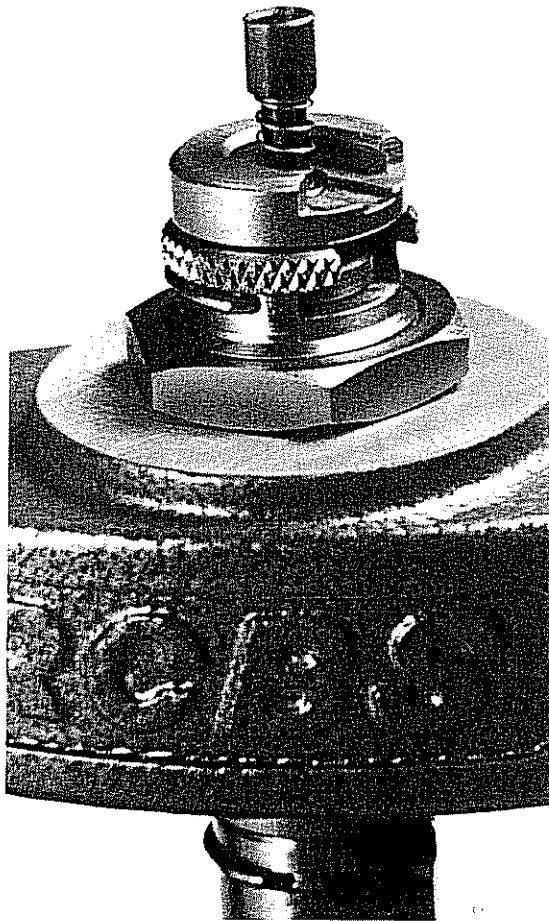

Fig. 2

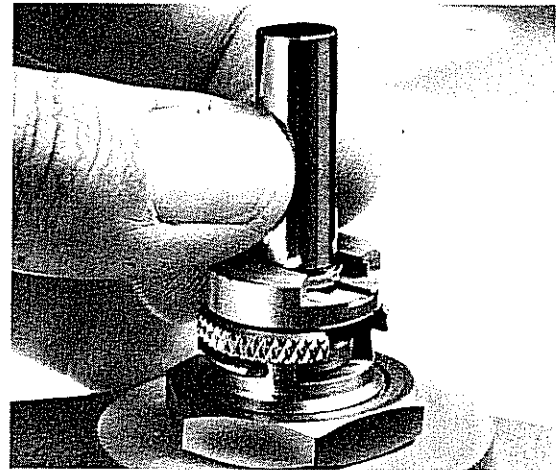

Fig. 3

WARNING: DO NOT ATTEMPT TO PRIME MILITARY CARTRIDGE CASES WITH CRIMPED PRIMER POCKETS UNTIL THE CRIMP HAS BEEN REMOVED WITH A COUNTER SINK, A SPECIAL REAMER OR BY SWAGING. PRIMERS SEATED INTO CRIMPED POCKETS ARE SUBJECT TO DEFORMATION WHICH CAN CAUSE MISFIRES AND EVEN DETONATION DURING SEATING WHICH CAN CAUSE PERSONAL INJURY.

WARNING: DO NOT ATTEMPT TO SEAT PRIMERS AGAINST EXCESSIVE RESISTANCE WHICH MIGHT CAUSE DETONATION AND POSSIBLE PERSONAL INJURY. CHECK TO BE CERTAIN THAT THE CASE WAS NOT PREVIOUSLY PRIMED, THAT THE FIRED PRIMER WAS REMOVED, THAT A PORTION OF THE PRIMER CUP WALL MIGHT STILL BE IN THE PRIMER POCKET AND THAT YOU ARE USING THE CORRECT SIZE PRIMER.

WARNING: DO NOT MODIFY THE PRIMING SYSTEM IN ANY MANNER OR ATTEMPT TO USE SIMILAR PARTS OR PRIMING SYSTEMS FROM OTHER MANUFACTURERS. TO DO SO COULD RESULT IN PRIMER DETONATIONS RESULTING IN PERSONAL INJURY.

WARNING: NEVER SEAT A PRIMER INTO A POWDER CHARGED CASE.

WARNING: DECAPPING LIVE PRIMERS IS EXTREMELY DANGEROUS AND IS NOT RECOMMENDED.

MAINTENANCE

This press was lubricated at the factory. However, it is necessary to lubricate all moving parts from time to time with a gun oil. If rust spots appear, swab lightly with gun oil and wipe dry. Care should be taken not to apply oil where it could come in contact with primer pockets or primers. Oil will deactivate primers. It is a good practice to clean the press prior to lubrication to remove grit and other residue. You will note the ease at which the epoxy enamel paint wipes clean. This finish is impervious to oil and is extremely chip and fade resistant.

RELOADER SPECIAL 3 PRESS PARTS LIST

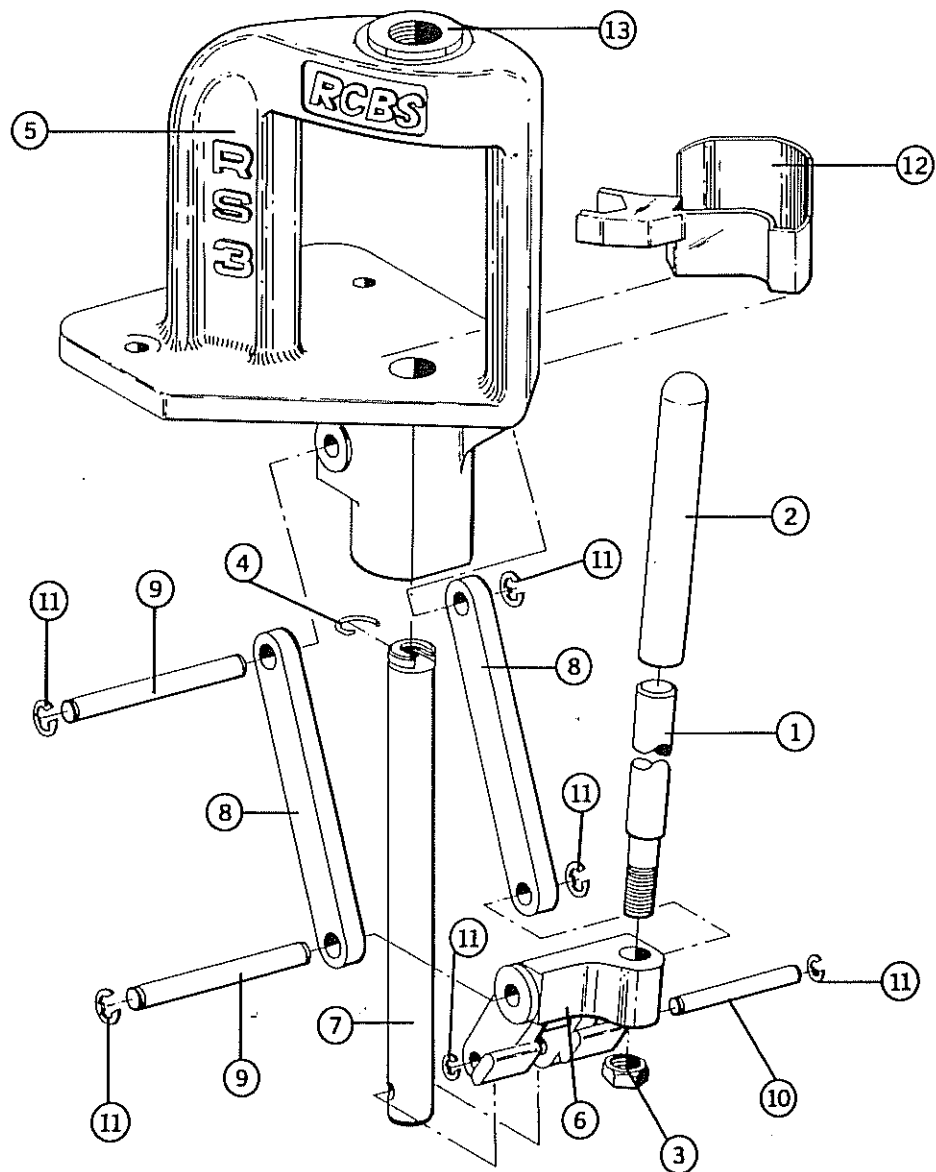

KEY	PART #	DESCRIPTION
1	09267	Handle
2	09264	Handle Grip
3	09265	Hex Nut $\frac{9}{16}$ -18
4	09111	Shell Holder Spring
5	09257	Frame
6	09258	Toggle
7	09259	Ram
8	09261	Link (2)
9	09262	Link Pin (2)
10	09263	Ram Pin
11	09266	Retaining Ring $\frac{3}{8}$ " (6)
12	09268	Primer Catcher
13	09138	Bushing
	09269	Grip Handle Assembly (not shown)
	86850	Ball Handle Assembly (not shown)
	86854	Spade Handle Assembly (not shown)

RAM™. PRIMING UNIT PARTS LIST

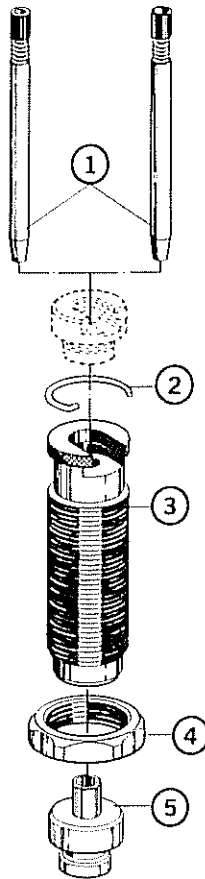

KEY	PART #	DESCRIPTION
1	09471	Primer Rod Assembly, Lg. & Sm.
2	09111	Shell Holder Spring
3	09175	Ram Priming Body
4	09021	Hex Lock Nut $\frac{7}{8}$ -14
5	09176	Primer Rod Holder

Standard Shell Holder not supplied with Ram Priming Unit

PLASTIC AMMO BOXES FROM RCBS

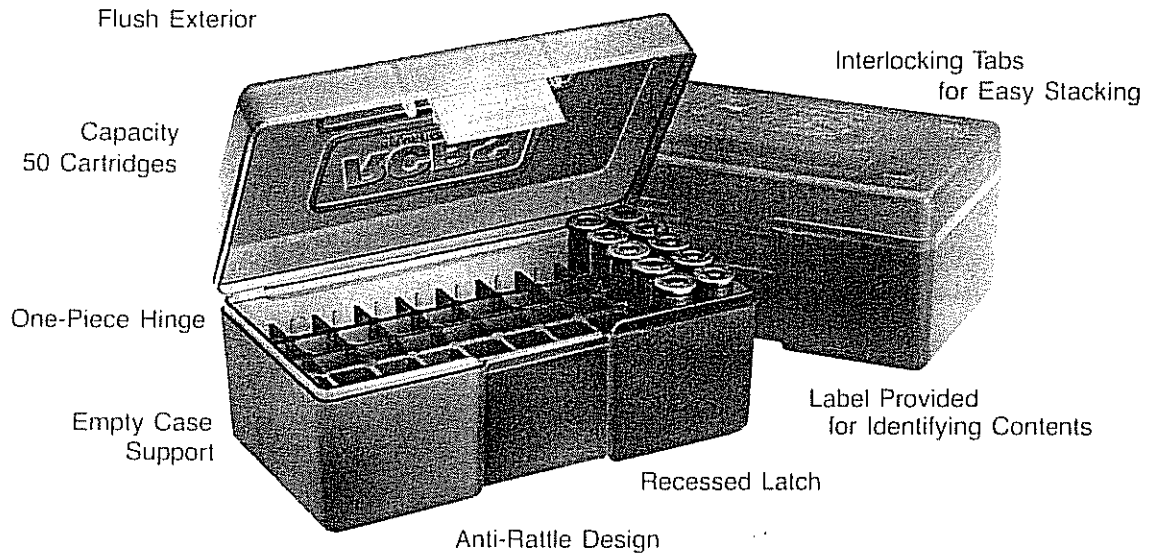

How can anyone improve on something as basic as a plastic box? We figured out about eight ways and included them in five different sized ammo boxes. RCBS plastic ammo boxes offer unique features that make all others obsolete. Great for securely packing, storing, carrying and dispensing most popular rifle or pistol cartridges. See your local gun dealer for these and other reloading accessories available from RCBS.



GET THE WHOLE SHOOTIN' MATCH
FROM THE GOOD OL' BOYS.
CCI, Speer, RCBS, Outers & Weaver

We think that we make the very best reloading equipment in the world. If you agree, please tell your friends. If you disagree, tell us — we want to do something about it!

RCBS Operations, 605 Oro Dam Blvd., Oroville, CA 95965